

ENGLISH

Introduction	3
Care and maintenance	3
Warning	4
Hearing loss	4
Safety	4
Technical specifications	4
AUDIO	4
CONNECTIVITY	4
MICROPHONE WITH HANDS-FREE FUNCTION	4
BATTERY	4
Product content	4
General overview	4
Switching on and off the device	5
Charging the battery	6
Bluetooth pairing	6
Playback control	6
Call control	6
Answering a call	6
Ending a call	6
Rejecting a call	6
Using the Voice Assistant feature	6
Warranty	7
Declaration of conformity	7

ENERGY♥SYSTEM

**sport1+**Manual de usuario / User manual
Manual de l'utilisateur / Manual do usuário

Introduction

- Thank you for trusting our company and buying the new *Earphones Bluetooth Sport 1+*. We hope you enjoy the product.
- Bluetooth 5.1 earphones for sport and sound lovers. Control Talk and Voice Assistant to answer your calls and control your music. Secure-Fit, USB Type-C connector and splashproof protection. Total comfort.

Care and maintenance

- Do not expose your *Earphones Bluetooth Sport 1+* to impacts, dust, humidity or high temperatures.
- Do not use neither corrosive nor abrasive cleaning products.
- Do not disassemble the device. All repair works should be carried out exclusively by qualified staff of Energy Sistem Technology, S.A.
- Please make sure your *Earphones Bluetooth Sport 1+* are off when you are not using them. Do not store them with an empty battery for long periods of time.

Warning

Hearing loss

Listening to loud music can cause irreversible hearing loss. To avoid hearing damage, we recommend the following guidelines:

- Do not listen to loud music for long periods of time.
- Turn the volume down on the source device before using the headphones, then gradually increase the volume to a safe volume level.

Safety

For safety reasons and to avoid possible accidents, we recommend the following safety measures:

- Do not use the headphones while driving or carrying out any other activity that requires special attention.
- Keep the product, packaging and accessories out of the reach of children and pets to avoid accidents and choking hazard.

Technical specifications

AUDIO

- Frequency response: 20 Hz - 20 kHz
- Diameter: 13 mm
- In-ear design
- Type: dynamic

CONNECTIVITY

- Bluetooth 5.1, class 2
- Frequency band: 2.4 GHz
- Maximum output power: < 20.00 dBm
- Compatible Bluetooth profiles: HSP / HFP / A2DP / AVRCP
- Up to 20 m distance range

MICROPHONE WITH HANDS-FREE FUNCTION

- Sensitivity: -42 dB ± 3 dB (@1 kHz)
- Type: built-in MEMS microphone

BATTERY

- Capacity: 100 mAh
- Type: lithium polymer
- Playback battery life: up to 8 hours
- Charging method: USB Type-C
- Charging time: 1.5 hours

Product content

- Earphones Bluetooth Sport 1+
- USB Type-C cable
- Interchangeable ear tips

Important: We recommend trying out the provided ear tips in different sizes to choose the ones that fit your ears best. Using ear tips that don't fit correctly may have an impact on the perceived sound quality.

General overview

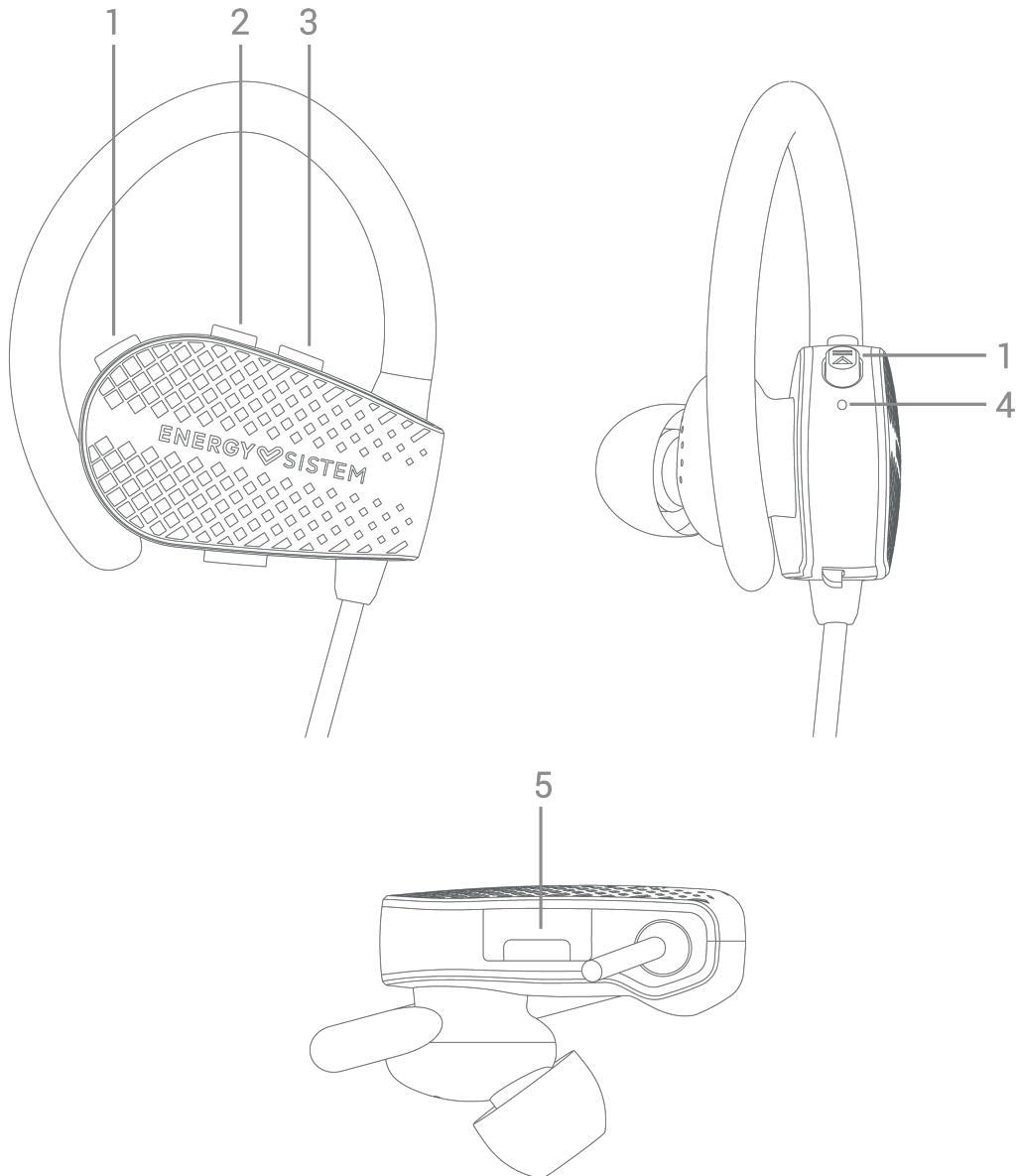

1. MULTIFUNCTION BUTTON
2. VOLUME - / BACK
3. VOLUME + / NEXT
4. LED INDICATOR / MICROPHONE
5. CHARGING PORT

Switching on and off the device

To turn on your device, press and hold the *MULTIFUNCTION BUTTON (1)* for 2 seconds and the *LED INDICATOR (4)* will light white. You will hear a confirmation sound when you switch it on. The *LED INDICATOR (4)* will keep flashing white as long as the device is on.

To turn off your device, press and hold the *MULTIFUNCTION BUTTON (1)* for 3 seconds. You will hear a sound when switching off the earphones.

Charging the battery

When the battery level is below 10%, the *LED INDICATOR (4)* will flash white. You will also hear a sound to remind you to charge the battery through the *CHARGING PORT (5)*.

Plug the USB Type-C end of the included USB cable into the *CHARGING PORT (5)* and connect the other USB end to any device with a USB charging port that provides energy (PC, USB wall charger, car charger, etc) to charge the battery.

The *LED INDICATOR (4)* glows white while charging the device and turns off once the charging process has been completed.

Important: We recommend not leaving your *Earphones Bluetooth Sport 1+* unused for long periods of time with an empty battery. We advise charging the battery at least once a month.

Bluetooth pairing

Switch on your *Earphones Bluetooth Sport 1+* and wait for approximately 4 seconds until the *LED INDICATOR (4)* starts flashing white. At this point, your earphones start searching for devices and can be paired with your music player. Once "Energy Sistem EP Sport 1+" appears on your device screen, press "connect". Both devices will be connected immediately and without codes. You will hear a sound that confirms both devices have been paired correctly.

To pair your earphones with the same music player once again, you don't need to repeat the steps above. Just leave Bluetooth enabled on your music player and switch on your *Earphones Bluetooth Sport 1+*. They will sync automatically.

Press and hold the *MULTIFUNCTION BUTTON (1)* for 8 seconds to disconnect the devices and pair your earphones with a new device.

Playback control

Press the *VOLUME + (3)* or *VOLUME - (2)* buttons to adjust the playback volume. You will hear a beep when reaching the maximum volume.

Press the *MULTIFUNCTION BUTTON (1)* to pause or resume playback.

Press *NEXT (3)* or *BACK (2)* for 2 seconds to skip to the next or previous track.

Call control

Once the *Earphones Bluetooth Sport 1+* and your smartphone are synchronised, you can control calls from the earphones.

Answering a call

Press the *MULTIFUNCTION BUTTON (1)* once to answer a call.

Ending a call

Press the *MULTIFUNCTION BUTTON (1)* once to end a call.

Rejecting a call

Press the *MULTIFUNCTION BUTTON (1)* for approximately 2 seconds to reject an incoming call.

Using the Voice Assistant feature

You can interact with your smartphone voice assistant using your *Earphones Bluetooth Sport 1+*. To do so, press the *MULTIFUNCTION BUTTON (1)* twice. You can give the voice command after hearing the confirmation sound.

Warranty

You can check the warranty terms here:

<https://www.energysistem.com/terms-warranty>

Declaration of conformity

Issuer's name: Energy Sistem Technology, S.A. - CIF: A53107488

Address: C/ Calpe, 1 - 03509 Finestrat, Alicante (Spain)

Tel: +34 966 830 324

We declare under our sole and exclusive responsibility that the product

Description: wireless sport earphones

Brand: Energy Sistem

Model: Earphones Bluetooth Sport 1+

Manufacturer: Energy Sistem Technology, S.A.

Manufacturing country: China

referred to in this declaration complies with the essential norms and standards

EN 300 328 V2.1.1

EN 301 489-1 V2.2.0

EN 301 489-17 V3.2.0

EN 62479:2010

EN 60950-1:2006+A11:2009+A1:2010+A12:2011+A2:2013

in conformity with the provisions of the Directive 2014/53/EU of the European Parliament and of the Council of 16th April 2014.

Finestrat, 1st July 2021



Miguel Ángel Aragüez García
Innovation and Technology Director

